

**BP 810 PREMIUM / LYNX****DESENLLANTADORA 3 PEDALES**

BP 810 PREMIUM / LYNX

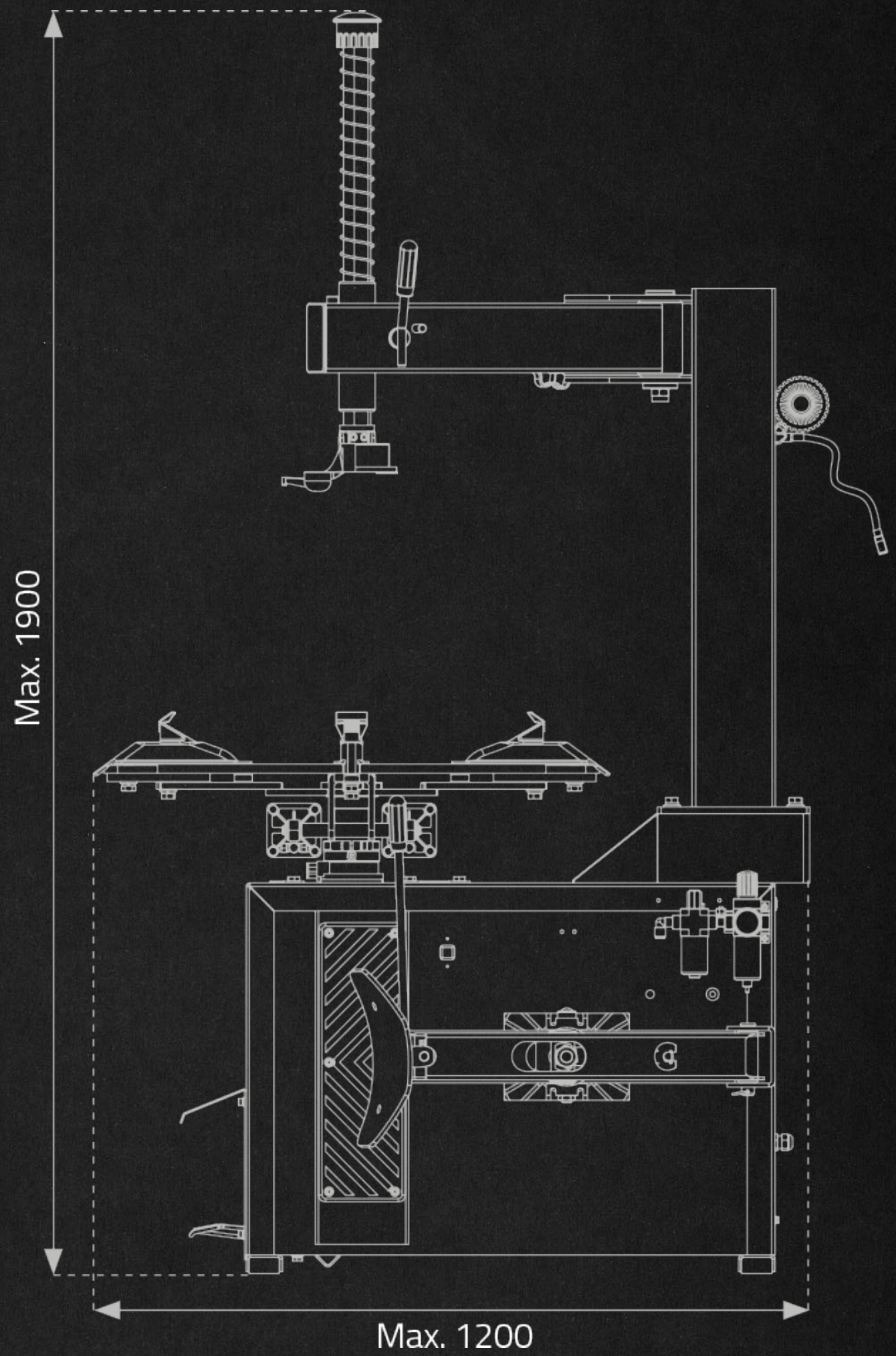
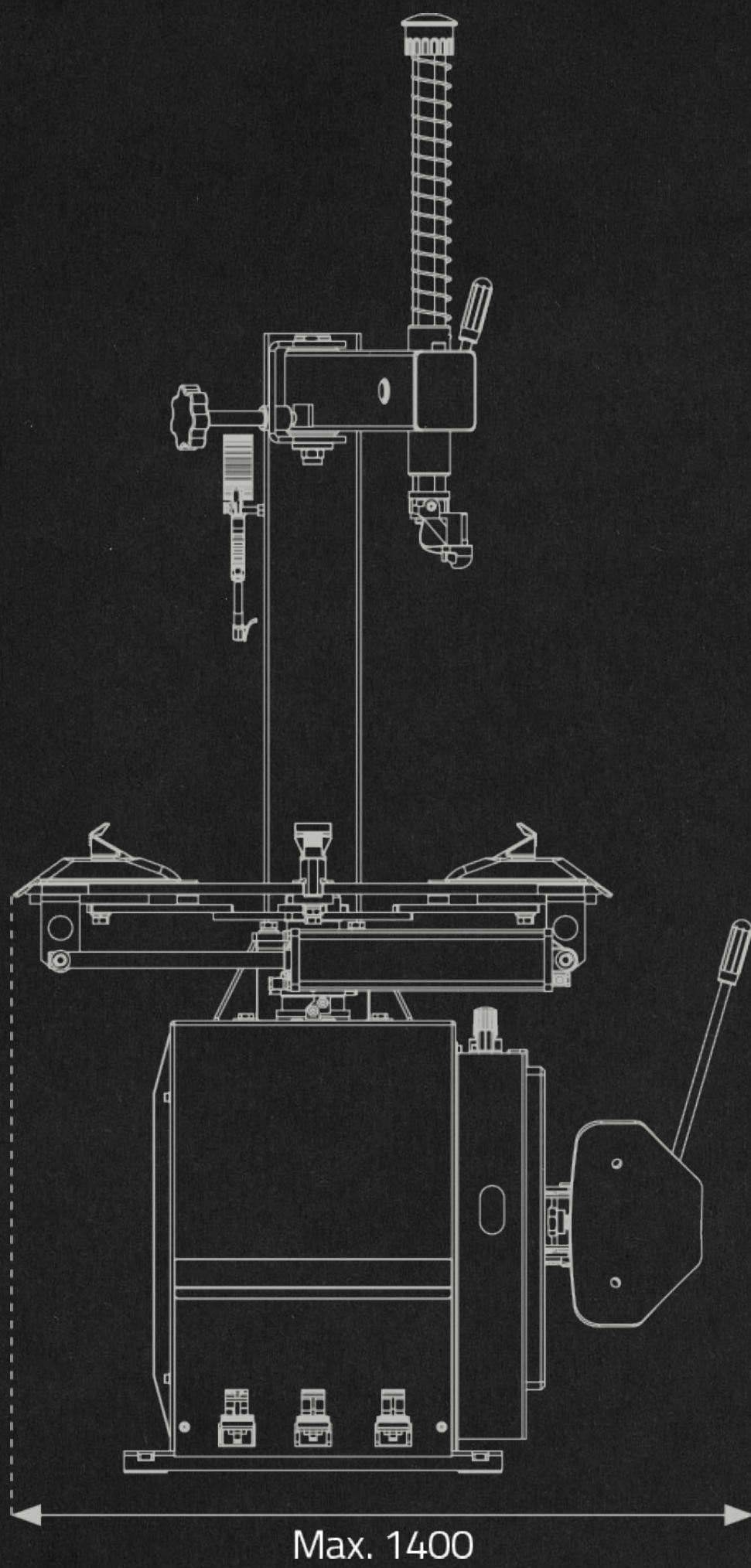

Especificación

EN

ES



## Technical data / Datos Técnicos

Outside clamp / Agarre exterior	10" - 20" inch
Inside clamp / Agarre interior	12" - 23" inch
Max. wheel diameter / Max. diámetro del Rim / Aro	960 mm
Tire width / Ancho del Rim / Aro	3" - 12" inch
Turntable configuration / Forma del plato	20" forma arco
Turntable rotation speed / Velocidad de giro del plato	6,5 rpm
Turntable ram cylinder diameter / Diametro del cilindro	70 mm
Working air pressure / Presión de aire	8 - 10 bar
Bead breaker force / Fuerza del destalonador	2500 kg
Power supply voltage / Voltaje	230v/1Ph-60 Hz
Power / Motor	1.1kW
Noise / Ruido	<70 dB
Dimensions (LxWxH) / Dimensiones	1200 x 1100 x 1900 mm
Color / Color	Negro
Nett weight / Peso neto	179 kg
Gross weight / Peso bruto	207 kg

